



# **GNSS ANTENNAS**



## High Rejection 26 dB with Enhanced Narrow Band Filtering

The GPS-TMG-HR-26 timing reference antennas feature a 26 dB amplifier and narrow band high rejection filtering specifically designed to support long-lasting, trouble-free deployments in congested cell-site applications with severe interference around the GPS L1 frequency.

The proprietary quadrifilar helix design, coupled with multi-stage filtering provides superior out-of-band rejection and lower elevation pattern performance than traditional patch antennas.

The unique radome shape sheds water and ice, while eliminating problems associated with bird perching. The antenna may be purchased by itself or with pipe mounting hardware. Custom models or site kits options are also available. The antenna label and collar mount are color coded red for differentiation purposes.

This antenna is made of materials that fully comply with provisions stipulated by EU directives RoHS 2002/95/EC.



GPS-TMG-HR-26N (Top)  
GPS-TMG-MNT-R (Bottom left)  
GPS-TMG-HR-26NCM (Bottom right)

### STANDARD CONFIGURATION

Model	Connector	Mount	Radome
GPS-TMG-HR-26N	N Female (one - bottom fed)	Antenna Only. Does not include mounting hardware.	Color: White
GPS-TMG-HR-26NCM		Includes red powder coated collar mount (GPS-TMG-MNT-R)	

### ELECTRICAL SPECIFICATIONS - GNSS ANTENNA

Model	Frequency Range	LNA Gain	Element Gain	Out of Band Rejection	VSWR
GPS-TMG-HR-26N	1575.42 +/- 10 MHz	26.5 dB ± 3 dB	3.5 dBic	≥ 65 dB @ 1559 MHz ≥ 65 dB @ 1625 MHz	≤ 1.5:1 (typical)

### ELECTRICAL SPECIFICATIONS - GNSS ANTENNA, continued

Model	Noise Figure	Current Draw	DC Voltage	Nominal Impedance	Polarization
GPS-TMG-HR-26N	≤ 4.0 dB @ +25°C (typ.) ≤ 4.5 dB @ +25°C (max.)	≤ 40 mA @ 5V	Operating: 3.3- 12.0 V (regulated) Survival: 24 V	50 ohms	Right hand circular

### MECHANICAL & ENVIRONMENTAL SPECIFICATIONS

Model	Dimensions	Weight	Housing Material	Temperature Range	Humidity
GPS-TMG-HR-26N	5.0" H x 3.2" D (126 H x 81 mm)	0.6 lbs (0.3 kg)	ASA	- 40°C to + 85°C	95%

## Global GNSS Timing Reference Antenna

GNSS Systems Covered: GPS L1, GALILEO E1, GLONASS L1 & BEIDOU B1

PCTEL's GNSS1-TMG-26N global GNSS timing reference antennas are specifically designed for long-lasting, trouble-free deployments in congested cell-site applications. The low noise, high gain amplifier is well suited to address attenuation issues associated with applications requiring longer cable runs.

The proprietary quadrifilar helix design, coupled with multi-stage filtering provides superior out-of-band rejection and lower elevation pattern performance than traditional patch antennas. This multi-band antenna covers GPS L1, GALILEO E1, GLONASS L1 as well as BEIDOU B1 frequencies.

Their unique radome shape sheds water and ice, while eliminating problems associated with bird perching. PCTEL offers an array of compatible mounting configurations. Custom models or site kits options are also available.

The antenna features transient voltage suppression as well as protection from reverse polarity and electrostatic discharge (ESD).



GNSS1-TMG-26N (Top)  
GPS-TMG-MNT (Bottom left)  
GPS-TMG-LMNT (Bottom right)

### STANDARD CONFIGURATION

Model	Connector	Mount*	Radome
GNSS1-TMG-26N	N Female (one - bottom fed)	Does not include mounting hardware.	Color: White
GNSS1-TMG-26NMS		Includes universal mounting hardware consisting of collar (GPS-TMG-MNT) and pipe clamp (GPS-TMG-LMNT)	
GNSS1-TMG-26NCM		Includes collar mount (GPS-TMG-MNT)	
GNSS1-TMG-26NCS		Includes economy collar marine mount (GPS-TMG-MRNMNT)	

### ELECTRICAL SPECIFICATIONS - GNSS ANTENNA

Model	Frequency Range	LNA Gain	Element Gain	Out of Band Rejection	VSWR
GNSS1-TMG-26N	1554-1615 MHz	26.5 dB $\pm$ 3 dB @ GPS L1/GALILEO E1 24.5 dB $\pm$ 3 dB @ GLONASS L1/BEIDOU B1	$\geq$ 3 dBic	$\geq$ -45 dB @ $f \leq$ 1530 MHz $\geq$ -45 dB @ $f \geq$ 1660 MHz	$<$ 2.0:1

### ELECTRICAL SPECIFICATIONS - GNSS ANTENNA, continued

Model	Noise Figure	Current Draw	DC Voltage	Nominal Impedance	Polarization
GNSS1-TMG-26N	$<$ 2.5 dB @ +25°C including pre-selector	$<$ 35 mA	3.0-9.0 V (operating) $\leq$ 28.0 V (survivability)	50 ohms	Right hand circular

### MECHANICAL & ENVIRONMENTAL SPECIFICATIONS

Model	Dimensions	Weight	Housing Material	Temperature Range	Humidity
GNSS1-TMG-26N	5.0" H x 3.2" D (126 H x 81 mm)	0.6 lbs (0.3 kg)	ASA	-40°C to +85°C	95%

\*All mounting options fit pipes of 1"-1.45" (25-37 mm) maximum diameter.



## 40 dB GPS L1/GLONASS L1/GALILEO E1 Timing Antenna with Integrated Lightning Protection

The GPSSL-TMG-SPI-40NCB timing reference antennas are specifically designed for long-lasting, trouble-free deployments in congested cell-site applications. The low noise, high gain amplifier is well suited to address attenuation issues associated with applications requiring longer cable runs.

The proprietary quadrifilar helix design, coupled with multi-stage filtering provides superior out-of-band rejection and lower elevation pattern performance than traditional patch antennas. This multi-band antenna covers GPS L1, GALILEO L1 as well as GLONASS E1 frequencies.

Their unique radome shape sheds water and ice, while eliminating problems associated with bird perching. The antenna comes with surge compliant mounting that addresses industry grounding requirements. Custom models or site kit options are also available.

This antenna is made of materials that fully comply with provisions stipulated by EU directives RoHS 2002/95/EC. The antenna provides integrated, on-board lightning protection capability that alleviates the need for downstream, in-line surge suppressors. The antenna also features ESD, reverse polarity protection and transit voltage suppression.



GPSSL-TMG-SPI-40NCB

### STANDARD CONFIGURATION

Model	Connector	Mount	Radome
GPSSL-TMG-SPI-40NCB	N Female (one - bottom fed)	Fits pipes of 1"-1.45" (25-37 mm) maximum diameter. Medium duty mount (GPS-TMG-MMD), grounding screw, and lug nut included.	Color: White

### ELECTRICAL SPECIFICATIONS - GNSS ANTENNA

Frequency Range	LNA Gain	Element Gain	Polarization	Out of Band Rejection
1590 ± 30 MHz	40 dB ± 4 dB @ GPS L1 & GALILEO E1 38 dB ± 4 dB @ GLONASS L1	≥ 3 dBic	Right hand circular	≥ -60 dB @ f ≤ 1530 MHz ≥ -60 dB @ f ≥ 1660 MHz

### ELECTRICAL SPECIFICATIONS - GNSS ANTENNA, continued

Noise Figure	Current Draw	DC Voltage	VSWR	Nominal Impedance
< 2.5 dB @ +25°C including pre-selector (maximum)	< 40 mA	3.3-9.0 V (operating) ≤ 28.0 V (survivability)	< 2.0:1	50 ohms

### MECHANICAL & ENVIRONMENTAL SPECIFICATIONS

Dimensions	Weight	Housing Material	Lightning Protection	Temperature Range	Humidity
7.25" H x 3.20" D (184 x 81 mm)	0.75 lbs (0.34 kg)	ASA	Per EN61000-4-5 Level 4	-40°C to +85°C	95%

## 40 dB Amplifier with Integrated Lightning Protection

The GPSL1-TMG-SPI-40NCB timing reference antennas are specifically designed for long-lasting, trouble-free deployments in congested cell-site applications. The low noise, high gain amplifier is well suited to address attenuation issues associated with applications requiring longer cable runs.

The proprietary quadrifilar helix design, coupled with multi-stage filtering provides superior out-of-band rejection and lower elevation pattern performance than traditional patch antennas.

Their unique radome shape sheds water and ice, while eliminating problems associated with bird perching. The antenna comes with surge compliant mounting that addresses industry grounding requirements. Custom models or site kit options are also available.

This antenna is made of materials that fully comply with provisions stipulated by EU directives RoHS 2002/95/EC.

The antenna provides integrated, on-board lightning protection capability that alleviates the need for downstream, in-line surge suppressors. The antenna also features ESD, reverse polarity protection and transit voltage suppression.



GPSL1-TMG-SPI-40NCB

### STANDARD CONFIGURATION

Model	Connector	Mount	Radome
GPSL1-TMG-SPI-40NCB	N Female (one - bottom fed)	Medium duty mount (GPS-TMG-MMD), a grounding screw, and lug nut are included	Color: White

### ELECTRICAL SPECIFICATIONS - GNSS ANTENNA

Frequency Range	LNA Gain	Element Gain	Polarization	Out of Band Rejection
1575.42 ± 10 MHz	40 dB ± 4 dB	3.5 dBic	Right hand circular	≥ -60 dB @ ± 50 MHz off center frequency

### ELECTRICAL SPECIFICATIONS - GNSS ANTENNA, continued

Noise Figure	Current Draw	DC Voltage	VSWR	Nominal Impedance
< 2.5 dB @ +25°C including pre-selector (maximum)	< 30 mA @ 5 V	3.3-9.0 V (operating) ≤ 28.0 V (survivability)	< 2.0:1	50 ohms

### MECHANICAL & ENVIRONMENTAL SPECIFICATIONS

Dimensions	Weight	Housing Material	Lightning Protection	Temperature Range	Humidity
7.25" H x 3.20" D (184 x 81 mm)	0.75 lbs (0.34 kg)	ASA	Per EN61000-4-5 Level 4	-40°C to +85°C	95%

## 26 dB Internal Amplifier

The GPS-TMG-26 timing reference antennas feature a 26 dB amplifier specifically designed to support long-lasting, trouble-free deployments in congested cell-site applications.

The proprietary quadrifilar helix design, coupled with multi-stage filtering provides superior out-of-band rejection and lower elevation pattern performance than traditional patch antennas.

Their unique radome shape sheds water and ice, while eliminating problems associated with bird perching. The antenna may be purchased by itself or with pipe mounting hardware. Custom models or site kits options are also available.

This antenna is made of materials that fully comply with provisions stipulated by EU directives RoHS 2002/95/EC.



GPS-TMG-26N (Top)  
GPS-TMG-MNT (Bottom left)  
GPS-TMG-LMNT (Bottom right)

### STANDARD CONFIGURATION

Model	Connector	Mount*	Radome
GPS-TMG-26N		Does not include mounting hardware.	
GPS-TMG-26NMS	N Female (one - bottom fed)	Includes universal mounting hardware consisting of collar (GPS-TMG-MNT) and pipe clamp (GPS-TMG-LMNT).	Color: White
GPS-TMG-26NCS		Includes collar mount (GPS-TMG-MRNMNT).	

### ELECTRICAL SPECIFICATIONS - GNSS ANTENNA

Model	Frequency Range	LNA Gain	Element Gain	Noise Figure	Current Draw
GPS-TMG-26N	1575.42 ± 10 MHz	26 dB ± 3 dB	3.5 dBic	≤ 2.5 dB @ +25°C including pre-selector	≤ 35 mA

### ELECTRICAL SPECIFICATIONS - GNSS ANTENNA, continued

Model	DC Voltage	VSWR	Nominal Impedance	Out-of-Band Rejection	Polarization
GPS-TMG-26N	3.3- 9.0 V (regulated)	< 2.0:1	50 ohms	≥ 60 dB @ +/- 50 MHz off center frequency	Right hand circular

### MECHANICAL & ENVIRONMENTAL SPECIFICATIONS

Model	Dimensions	Shipping Dimensions	Weight	Shipping Weight	Radome Color	Temperature Range	Humidity
GPS-TMG-26N	5.0" H x 3.2" D (126 H x 81 mm)	7.5" L x 4.4" W x 3.8" D (190 L x 112 x 96 mm)	0.6 lbs (0.3 kg)	1.9 lbs (0.9 kg)	White	- 40°C to + 85°C	95%

\* All mounting options fit pipes of 1"-1.45" (25-37 mm) maximum diameter.



## High Rejection Permanent Mount GPS Antenna

The 3971D-HR-DH-W, permanent mount GPS Antenna provides 28 dB gain and superior out-of-band rejection performance and is the optimum choice for GPS Tracking and Timing applications with high RF fields. It features a precision tuned custom ceramic patch element for maximum signal reception, 15KV ESD circuit protection, multi and dual high rejection SAW filters. This enables the 3971D-HR-DH-W to provide a reliable and clear GPS signal while minimizing loss-of-lock, even when conditions are less than ideal. Available in an all-plastic, non-corrosive conical package for vehicle mounting or fixed installations.



3971D-HR-DH-W

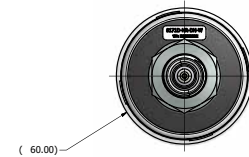
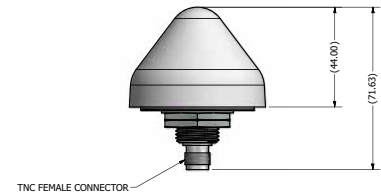

### Features

- Weather proof, all-plastic, non-corrosive, cone-shaped enclosure
- 3/4 inch thru-hole or bracket mount
- Unique radome sheds water and ice, while eliminating problems associated with bird perching
- Very high rejection dual SAW filter for superior out-of-band rejection
- Voltage range: 2.7 to 5.5 V
- Low current draw: 8 mA @ 3.3 VDC

### STANDARD CONFIGURATION

Model	Connector	Mount
3971D-HR-DH-W	TNC jack	3/4" thru-hole or bracket mount*

### ELECTRICAL SPECIFICATIONS - GNSS ANTENNA

Frequency Range	LNA Gain	Element Gain	Current Draw	DC Voltage	Noise Figure	Polarization	Out of Band Rejection
1575.42 ± 10 MHz	28 dB	3 dBic @ 90° -2 dBic @ 20°	8 mA @ 3.3 VDC	2.7-5.5 VDC	3.1 dB (typical)	Right hand circular	> 50 dBc @ ± 40 MHz

### MECHANICAL SPECIFICATIONS

Dimensions	Weight	Housing Material
2.36" Dia x 1.73" H (60 x 44 mm)	.11 lbs (50 g)	PC

### ENVIRONMENTAL SPECIFICATIONS

Temperature Range	ESD Circuit Protection	Ingress Protection
-40°C to +85°C operating	15 KV	IP67**

\* Order MMK1925 bracket for compatible mounting.  
\*\* When installed according to manufacturer's installation instructions.

# 8178D-HR-DH-W Time Sync, High Gain, High Rejection Antenna



PCTEL's GNSS High Rejection, High Gain Time Sync Antenna is a full GNSS band antenna covering GPS L1, GLONASS L1, Galileo E1 and Beidou B1 satellite frequency bands. PCTEL's proprietary filtering design allows wideband coverage while achieving superior out-of-band rejection and high gain 40 dB performance. This antenna comes in a small, conical form factor to minimize perching and provide runoff. The 8178D-HR-DH-W is equipped with a TNC female connector and is ideal for any global GNSS time synchronization application that requires an externally mounted antenna.

## Features

- GPS L1, GLONASS L1, Galileo E1 and Beidou B1 frequencies
- Industry leading out-of-band rejection
- 40 dB LNA gain
- Low noise figure < 2.0 dB
- Conical radome sheds water, ice, and minimizes bird perching

## Applications

- Carrier network timing / small cell
- Utility electric grid synchronization
- Positive train control (PTC) networks
- Broadcast digital TV networks
- Public safety communications
- Banking / financial time stamping



8178D-HR-DH-W

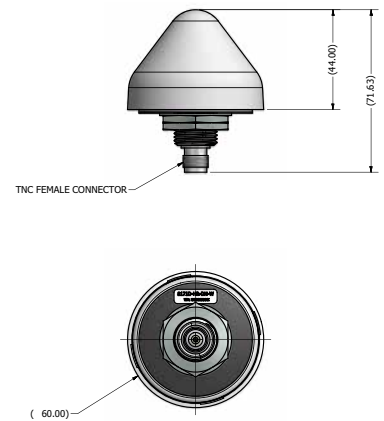

## ELECTRICAL SPECIFICATIONS - GNSS ANTENNA

Frequency Range	LNA Gain	Element Gain	Polarization	Out of Band Rejection
1559-1610 MHz	40 dB ± 4 dB	2 dBic @ 90°	Right hand circular	f0 = 1586 MHz f0 ± 50 MHz: ≥ 60 dBc f0 ± 60 MHz: ≥ 70 dBc

## ELECTRICAL SPECIFICATIONS - GNSS ANTENNA, continued

Current Draw	DC Voltage	Noise Figure	VSWR	Nominal Impedance
< 25 mA (typical)	2.8-6.0 V (operating) ≤ 12.0 V (survivability)	< 2.0 dB (typical)	2.0:1 (typical)	50 ohms

## MECHANICAL SPECIFICATIONS

Dimensions	Weight	Housing Material	Mount	Connector
2.36" x 1.73" (60 x 44 mm)	0.1 lbs (50 g)	GE Lexan EXL9330	¾" thru-hole or bracket mount*	TNC Female

## ENVIRONMENTAL SPECIFICATIONS

Temperature Range	Vibration	Ingress Protection
-40°C to +85°C operating	3 axis, sweep = 15 min 10-200 Hz log sweep: 3G	IP67**

\* Order MMK1925 for compatible mounting. \*\* When installed according to the manufacturer's installation instructions.



## High Gain & High Rejection Permanent Mount GPS Antenna

The 3978D-HR-DH-W high gain, permanent mount GPS Antenna provides 40 dB gain and superior out-of-band rejection performance and is the optimum choice for GPS Tracking and Timing applications with long cable runs and stand alone GPS applications. It features a precision tuned custom ceramic patch element for maximum signal reception, 15KV ESD circuit protection, a multi-stage LNA circuit and dual high rejection SAW filters. This enables the 3978DHR- DH-W to provide a reliable and clear GPS signal while minimizing loss-of-lock, even when conditions are less than ideal. Available in an all-plastic, non-corrosive conical package for vehicle mounting or fixed installations.



3978D-HR-DH-W

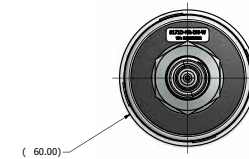
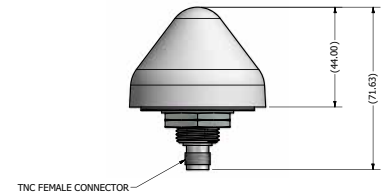

### Features

- Weather proof, all-plastic, non-corrosive, cone-shaped enclosure
- ¾ inch thru-hole or bracket mount
- Unique radome sheds water and ice, while eliminating problems associated with bird perching
- Very high rejection dual SAW filter for superior out-of-band rejection
- Voltage range: 2.7-5.5 V
- High gain: 40 dB (typical)

### STANDARD CONFIGURATION

Model	Connector	Mount
3978D-HR-DH-W	TNC jack	¾" thru-hole or bracket mount*

### ELECTRICAL SPECIFICATIONS - GNSS ANTENNA

Frequency Range	LNA Gain	Element Gain	Current Draw
1575.42 ± 10 MHz	40 dB	3 dBic @ 90° -2 dBic @ 20°	18 mA @ 3.3 VDC (typ.)

### ELECTRICAL SPECIFICATIONS - GNSS ANTENNA, continued

DC Voltage	Noise Figure	Polarization	Out of Band Rejection
2.7-5.5 VDC	3.1 dB (typical)	Right hand circular	> 50 dBc @ ± 40 MHz

### MECHANICAL & ENVIRONMENTAL SPECIFICATIONS

Dimensions	Weight	Housing Material	Temperature Range	ESD Circuit Protection	Ingress Protection
2.36" Dia x 1.73" H (60 x 44 mm)	0.11 lbs (50 g)	PC	-40°C to +85°C operating	15 KV	IP67**

\* Order MMK1925 bracket for compatible mounting.  
\*\* When installed according to manufacturer's installation instructions.

## Permanent Mount GPS Antenna

The 3977D permanent mount GPS value antenna provides 28 dB gain features a precision tuned custom ceramic patch element for maximum signal reception and 15KV ESD circuit protection. This enables the 3977D to minimize loss-of-lock, even when conditions are less than ideal. Available in an all-plastic, non-corrosive low-profile package for vehicle mounting in a white or dark gray housing.

### Features

- Weather proof, all-plastic, non-corrosive, low-profile enclosure
- 3/4 inch thru-hole or bracket mount
- Voltage range: 2.7 to 5.5 V
- High gain: 28 dB
- Low noise figure: 1.5 dB



3977D (Top)  
3977D-W (Bottom)

### STANDARD CONFIGURATION

Model	Connector	Mount	Radome
3977D 3977D-W	TNC Female	3/4" thru-hole or bracket mount*	Color: Black Color: White

### ELECTRICAL SPECIFICATIONS - GNSS ANTENNA

Frequency Range	LNA Gain	Element Gain	Out of Band Rejection
1575.42 MHz ± 10 MHz	@ 3.3VDC: 28 dB @ 5VDC: 30 dB	3 dBic @ 90° -2 dBic @ 20°	> 30dB @ ± 30 MHz

### ELECTRICAL SPECIFICATIONS - GNSS ANTENNA, continued

Current Draw	DC Voltage	Noise Figure	Polarization
<20mA @ 3.3v <35mA @ 5.0v	2.7-5 VDC	1.5 dB (typical)	Right hand circular

### MECHANICAL SPECIFICATIONS

Dimensions	Weight	Housing Material
2.36" Dia x 0.83" H (60 x 21 mm)	0.11 lbs (50 g)	PC

### ENVIRONMENTAL SPECIFICATIONS

Temperature Range	ESD Circuit Protection	Ingress Protection
-40°C to +85°C operating	15 KV	IP67

\* Order MMK1925 bracket for compatible mounting

# Mobile Mount, Low-Profile Active, 28 dB GPS Antenna



PCTEL's GPS active NMO mount antenna provides superior performance with the industry's smallest NMO mountable footprint. The GPS-NMO antenna features a custom tuned frequency ceramic patch element, 15 KV ESD circuit protection, a two-stage low noise amplifier and a SAW filter, that provides excellent out-of-band signal rejection performance and consistently clear signal while minimizing loss-of-lock.

The GPS-NMO features an attractive, compact housing environmentally tested for both fixed or mobile applications. Its innovative tab design supports higher reliability and repeatable performance at GPS frequencies than button pin designs can provide. The product is available in black or white housing options to suit a wide variety of installation applications.



GPS-NMO



GPS-NMO-W (White)

### Features

- Attractive, low-profile design for maximum overhead clearance
- 2.7-5 Volt operation
- 15 KV ESD circuit protection
- Mates with all 1-1/8"-18 thread NMO mounts, including 3/4" mounts

## STANDARD CONFIGURATION

Model	Mount	Radome
GPS-NMO	Does not include mounting hardware.	Black
GPS-NMO-W	Compatible with all 1-1/8"-18 thread NMO mounts, including 3/4" mounts*.	White

## ELECTRICAL SPECIFICATIONS - GNSS ANTENNA

Model	Frequency Range	LNA Gain	Element Gain	Noise Figure	Out of Band Rejection
GPS-NMO	1575.42MHz ±10 MHz	@ 3.3VDC: 28 dB @ 5VDC: 30 dB	1 dBic	1.5 dB (typical)	± 15 MHz: 5 dB ± 20 MHz: 10 dB ± 30 MHz: 32 dB ± 40 MHz: 40 dB

## ELECTRICAL SPECIFICATIONS - GNSS ANTENNA, continued

Model	Current Draw	DC Voltage	Nominal Impedance	Polarization
GPS-NMO	<20mA @ 3.3v <35mA @ 5.0v	2.7 - 5 VDC	50 ohms	Right hand circular

## MECHANICAL & ENVIRONMENTAL SPECIFICATIONS - GNSS ANTENNA

Model	Dimensions	Weight	Shock	Vibration	Temperature Range	Humidity
GPS-NMO	1.5" x 1.8" (38 x 46 mm)	0.15 lbs (0.07 kg)	Vertical axis 50G, Other axes 30G	3 axis, sweep = 60 min 3 - 500 Hz random vibration	-40°C to +85°C operating	95% max (non condensing)

\*PCTEL is a leading designer and manufacturer of custom mobile mount assemblies. Please contact PCTEL Customer Service for your custom solutions.

## High Rejection Low-Profile Permanent Mount GPS Antenna

The 3971D-HR, low-profile permanent mount GPS antenna provides 28 dB gain and superior out-of-band rejection performance and is the optimum choice for GPS Tracking and Timing applications with high RF fields. It features a precision tuned custom ceramic patch element for maximum signal reception, 15KV ESD circuit protection, a multi-stage LNA circuit and dual high rejection SAW filters. This enables the 3971D-HR to provide a reliable and clear GPS signal while minimizing loss-of-lock, even when conditions are less than ideal. Available in an all-plastic, non-corrosive conical package for vehicle mounting or fixed installations.



3971D-HR

### Features

- Weather proof, all-plastic, non-corrosive, low-profile enclosure
- ¾ inch thru-hole or bracket mount
- High out-of-band rejection for stand-alone or mobile applications where interference is a concern and performance is critical
- Innovative dual SAW filter design
- Voltage range: 2.7 to 5.5 V
- Low current draw: 8 mA @ 3.3 VDC

### STANDARD CONFIGURATION

Model	Connector	Mount
3971D-HR	TNC jack	¾" thru-hole or bracket mount*

### ELECTRICAL SPECIFICATIONS - GNSS ANTENNA

Frequency Range	LNA Gain	Element Gain	Polarization
1575.42 ± 10 MHz	28 dB	3 dBic @ 90° -2 dBic @ 20°	Right hand circular

### ELECTRICAL SPECIFICATIONS - GNSS ANTENNA, continued

Out of Band Rejection	Current Draw	DC Voltage	Noise Figure
> 50 dBc @ ± 40 MHz	8 mA @ 3.3 VDC	2.7-5.5 VDC	3.1 dB (typical)

### MECHANICAL & ENVIRONMENTAL SPECIFICATIONS

Dimensions	Weight	Housing Material	Temperature Range	ESD Circuit Protection	Ingress Protection
2.36" Dia x .83" H (60 x 21 mm)	0.11 lbs (50 g)	PC	-40°C to +85°C operating	15 KV	IP67**

\* Order MMK1925 bracket for compatible mounting.

## Very Low Noise Mobile GPS Antenna



The 3910D GPS antenna has one of the industry's lowest noise figures. It features ESD circuit protection, an innovative very low noise LNA and a high rejection SAW filter. It also features a precisely tuned custom ceramic patch element that minimizes detuning effects caused by adjacent objects. The 3910D is ideal for Fleet Management, Asset Tracking and Precision Agriculture as well any application with poor signal reception area.

The 3910D provides consistent, clear GPS signal reception while minimizing loss-of-lock in high-RF fields. Housed in a weatherproof magnetic or screw mount enclosure, the 3910D GPS antenna is ideal for demanding vehicle mounted GPS applications.



3910D

### Features

- Low noise: 0.5 dB
- Low current: 8mA
- Wide voltage input range (2.7 - 5 VDC)
- Robust IP67 housing built for various weather conditions

### STANDARD CONFIGURATION

Model	Cable	Connector	Mount
3910D	9.8' (3 meters) highly flexible 174 sized cable	Male SMA standard*	Magnetic (5 lb lift-off force) or permanent (pre-threaded for 3 x M2.5 screws)

### ELECTRICAL SPECIFICATIONS - GNSS ANTENNA

Frequency Range	LNA Gain	Element Gain	Polarization
1575.42 ± 10 MHz	28 dB @ 3.3 VDC	3 dBic @ 90° -2 dBic @ 20°	Right hand circular

### ELECTRICAL SPECIFICATIONS - GNSS ANTENNA, continued

Out of Band Rejection	Current Draw	DC Voltage	Noise Figure
> 30 dB @ ± 30 MHz	8 mA @ 3.3 V	2.7-5 VDC	0.5 dB (typical)

### MECHANICAL SPECIFICATIONS

Dimensions	Weight	Housing Material
2.05" L x 2.33" W x 0.54" H (52.1 x 59.2 x 13.6 mm)	0.29 lbs (130 g)	ASA

### ENVIRONMENTAL SPECIFICATIONS

Temperature Range	ESD Circuit Protection	Ingress Protection
-40°C to +85°C operating	15 KV	IP67

\* Consult PCTEL Customer Service for other connector options.



## Value Mobile GPS Antenna

The 3917D GPS antenna is a high performance value antenna with a wide voltage range, ideally suited to telematics platforms for use in vehicle-mounted applications. Using internal magnets or screw mount holes, the antenna can be installed almost anywhere on a vehicle allowing for greater flexibility. The 3917D antenna features 28 dB gain low noise amplifier and a SAW filter. With 2.7 to 5 volt operation, the antenna can be used with the vast majority of GPS systems available



3917D

### Features

- Voltage range 2.7-5 V
- LNA 28 dB gain typical
- Low noise figure 1.5 dB

### STANDARD CONFIGURATION

Model	Cable	Connector	Mount
3917D	9.8' (3 meters) highly flexible 174 sized cable	Male SMA standard*	Magnetic (5 lb lift-off force) or permanent (pre-threaded for 3 x M2.5 screws)

### ELECTRICAL SPECIFICATIONS - GNSS ANTENNA

Frequency Range	LNA Gain	Element Gain	Polarization	Out of Band Rejection
1575.42 ± 10 MHz	@ 3.3 VDC: 28 dB @ 5 VDC: 30 dB	3 dBic @ 90° -2 dBic @ 20°	Right hand circular	> 30 dB @ ± 40 MHz

### ELECTRICAL SPECIFICATIONS - GNSS ANTENNA, continued

Current Draw	DC Voltage	Noise Figure
<20mA @ 3.3v <35mA @ 5.0v	2.7-5 VDC	1.5 dB (typical)

### MECHANICAL SPECIFICATIONS

Dimensions	Weight	Housing Material
2.05" L x 2.33" W x 0.54" H (52.1 x 59.2 x 13.6 mm)	0.26 lbs (120 g)	ASA

### ENVIRONMENTAL SPECIFICATIONS

Temperature Range	ESD Circuit Protection	Ingress Protection
-40°C to +85°C operating	15 KV	IP67

\* Consult PCTEL Customer Service for other connector options.



## High Rejection Dual Filter Mobile GPS Antenna for High RF Noise Environments

The 3911D-HR low interference GPS Antenna with Dual SAW High Rejection Filters allow excellent performance in high RF noise environments as found on vehicles with multiple antennas. It is ideal for fleet tracking, public safety, transit, precision agricultural and military applications.

The 3911D-HR features ESD circuit protection, an innovative two-stage low noise amplifier and a dual SAW high rejection filter. It also features a custom designed ceramic patch element that minimizes detuning effects caused by adjacent objects. The 3911D-HR provides consistent, clear GPS signal reception while minimizing loss-of-lock in high-RF fields. Housed in a weatherproof magnetic or screw mount enclosure, the 3911D-HR GPS antenna is ideal for demanding vehicle mounted GPS applications.



3911D-HR

### Features

- High rejection dual SAW filters allow placement near other transmitting antennas
- Low current: 7.5 mA @ 3.3V
- Wide voltage input range (2.7 - 5 VDC)
- Robust IP67 housing built for various weather conditions

### STANDARD CONFIGURATION

Model	Cable	Connector	Mount
3911D-HR	16.4' (5 meters) highly flexible 174 sized cable	SMA standard*	Magnetic (5 lb lift-off force) or permanent (pre-threaded for 3 x M2.5 screws)

### ELECTRICAL SPECIFICATIONS - GNSS ANTENNA

Frequency Range	LNA Gain	Element Gain	Polarization
1575.42 ± 10 MHz	25 dB @ 3.3 VDC 25.5 dB @ 5 VDC	3 dBic @ 90° -2 dBic @ 20°	Right hand circular

### ELECTRICAL SPECIFICATIONS - GNSS ANTENNA, continued

Out of Band Rejection	Current Draw	DC Voltage	Noise Figure
> 50 dBc @ ± 40 MHz	7.5 mA @ 3.3V 11.5 mA @ 5V	2.7-5 VDC	3.1 dB

### MECHANICAL & ENVIRONMENTAL SPECIFICATIONS

Dimensions	Weight	Housing Material	Temperature Range	ESD Circuit Protection	Ingress Protection
2.05" L x 2.33" W x 0.54" H (52.1 x 59.2 x 13.6 mm)	0.29 lbs (130 g)	ASA	-40°C to +85°C operating	15 KV	IP67

\* Consult PCTEL Customer Service for other connector options.



## Low Power GPS Antenna with Dual High Rejection SAW Filters

The 3915D-HR Very Low Power High Rejection GPS Antenna has one of the industry's lowest power consumption and best out-of-band filter performance. The 3915D-HR features ESD circuit protection, an innovative very low power two-stage low noise amplifier and dual high rejection SAW filters. It also features a custom designed ceramic patch element that minimizes detuning effects caused by adjacent objects. The 3915D-HR provides consistent, clear GPS signal reception while minimizing loss-of-lock in high-RF fields. Housed in a weatherproof magnetic or screw mount enclosure, the 3915D-HR is ideal for most demanding, power critical GPS applications.



3915D-HR

### Features

- High rejection dual SAW filters allows placement near other transmitting antennas
- Low current: 1.3 mA @ 3.3V
- 20 dB gain
- Wide voltage input range (2.7 - 5 VDC)
- Robust IP67 housing built for various weather conditions

### STANDARD CONFIGURATION

Model	Cable	Connector	Mount
3915D-HR	16.4' (5 meters) highly flexible 174 sized cable	SMA standard*	Magnetic (5 lb lift-off force) or permanent (pre-threaded for 3 x M2.5 screws)

### ELECTRICAL SPECIFICATIONS - GNSS ANTENNA

Frequency Range	LNA Gain	Element Gain	Polarization
1575.42 ± 10 MHz	20 dB @ 3.3 VDC	3 dBic @ 90° -2 dBic @ 20°	Right hand circular

### ELECTRICAL SPECIFICATIONS - GNSS ANTENNA, continued

Out of Band Rejection	Current Draw	DC Voltage	Noise Figure
> 50 dBc @ ± 40 MHz	1.3 mA @ 3.3 V 2 mA @ 5 V	2.7-5 VDC	3.6 dBi

### MECHANICAL & ENVIRONMENTAL SPECIFICATIONS

Dimensions	Weight	Housing Material	Temperature Range	ESD Circuit Protection	Ingress Protection
2.05" L x 2.33" W x 0.54" H (52.1 x 59.2 x 13.6 mm)	0.26 lbs (120 g)	ASA	-40°C to +85°C operating	15 KV	IP67

\* Consult PCTEL Customer Service for other connector options.



## High Rejection Embedded GPS Antenna

The 3961D-HR Embedded GPS Antenna provides 25 dB gain, superior out-of-band rejection performance and is the optimum choice for embedded GPS Tracking and Timing applications with high RF fields. It features a precision tuned custom ceramic patch element for maximum signal reception, 15KV ESD circuit protection, a multi-stage LNA circuit and dual high rejection SAW filters. This enables the 3961D-HR to provide a reliable and clear GPS signal while minimizing loss-of-lock, even when conditions are less than ideal. The 3961D-HR comes with a 45.2 mm diameter mini ground plane.

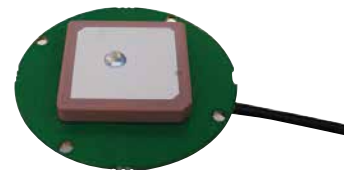

3961D-HR

### Features

- High out-of-band rejection for stand-alone or mobile applications where interference is a concern and performance is critical
- Innovative dual SAW filter design
- Low current draw: 7.5 mA @ 3.3 VDC
- Comes with internal ground plane
- 15 KV ESD circuit protection

### STANDARD CONFIGURATION

Model	Cable	Connector
3961D-HR	6" (15 cm) RG174*	MCX right angle*

### ELECTRICAL SPECIFICATIONS - GNSS ANTENNA

Frequency Range	LNA Gain	Element Gain	Polarization	Noise Figure
1575.42 ± 10 MHz	@ 3.3 VDC: 25 dB @ 5 VDC: 25.5 dB	3 dBic @ 90° -2 dBic @ 20°	Right hand circular	3.1 dB (typical)

### ELECTRICAL SPECIFICATIONS - GNSS ANTENNA, continued

Out of Band Rejection	Current Draw	DC Voltage	VSWR	Nominal Impedance
> 50 dBc @ ± 40 MHz	7.5 mA @ 3.3 VDC (typical)	2.7-5 VDC	2.0:1 maximum	50 ohms

### MECHANICAL SPECIFICATIONS

Dimensions	Weight
1.8" x 0.3" (45.2 x 7.7 mm)	0.56 oz (16 g)

### ENVIRONMENTAL SPECIFICATIONS

Temperature Range	ESD Circuit Protection	Humidity
-40°C to +85°C operating	15 KV	95% max (non condensing)

\* Consult PCTEL Customer Service for other connector options.

## Low Noise GPS Embedded Antenna

The 3961D Embedded GPS Antenna has one of the industry's lowest noise figures. It features a tuned custom ceramic patch element that minimizes detuning effects caused by adjacent objects. It also features ESD circuit protection, an innovative LNA (low noise amplifier) and a high rejection SAW filter which enable these antennas to provide a consistent, clear signal while minimizing loss-of-lock even when GPS conditions are less than ideal. The 3961D comes with a 45.2 mm diameter mini ground plane.

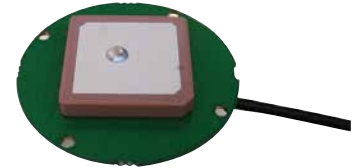

3961D

### Features

- Comes with internal ground plane
- 15 KV ESD circuit protection
- Low noise figure: 0.5 dB
- Ideal for embedded applications

### STANDARD CONFIGURATION

Model	Cable	Connector
3961D	6" (15 cm) RG174	MCX right angle

### ELECTRICAL SPECIFICATIONS - GNSS ANTENNA

Frequency Range	LNA Gain	Element Gain	Polarization	Noise Figure
1575.42 ± 10 MHz	@ 3.3 VDC: 28 dB @ 5 VDC: 30 DB	3 dBic @ 90° -2 dBic @ 20°	Right hand circular	0.5 dB (typical)

### ELECTRICAL SPECIFICATIONS - GNSS ANTENNA, continued

Current Draw	DC Voltage	VSWR	Nominal Impedance	Out of Band Rejection
7.5 mA @ 3.3 VDC (typical)	2.7-5.0 VDC	1.5:1 maximum	50 ohms	> 30 dB @ ± 40 MHz

### MECHANICAL SPECIFICATIONS

Dimensions	Weight
1.85" Dia x 0.32" H (47 x 8 mm)	0.56 oz (16 g)

### ENVIRONMENTAL SPECIFICATIONS

Temperature Range	ESD Circuit Protection	Humidity
-40°C to +85°C operating	15 KV	95% max (non condensing)



## Value Embedded GPS Antenna

The 3967D GPS antenna is ideal for ruggedized handheld GPS devices, mobile asset tracking equipment and GPS timing applications. The 3967D features a custom designed ceramic patch element, a two-stage low noise amplifier and a SAW filter, providing great out-of-band signal rejection performance, consistent and clear signal while minimizing loss-of-lock. The 3967D comes with a 1.85" mini-ground plane.

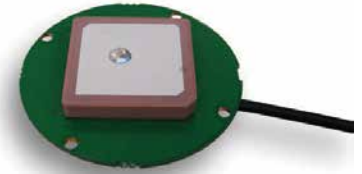

3967D

### Features

- 2.7 - 5 V operation
- 15 KV ESD circuit protection
- Comes with internal ground plane
- Ideal for embedded applications

### STANDARD CONFIGURATION

Model	Cable	Connector
3967D	6" (15 cm) RG174	MCX right angle

### ELECTRICAL SPECIFICATIONS - GNSS ANTENNA

Frequency Range	LNA Gain	Element Gain	Polarization	Out of Band Rejection	Current Draw
1575.42 ± 10 MHz	@ 3.3 VDC: 28 dB @ 5 VDC: 30 dB	3 dBic @ 90° -2 dBic @ 20°	Right hand circular	± 15 MHz: 5 dB ± 20 MHz: 10 dB ± 30 MHz: 32 dB ± 40 MHz: 40 dB	<20mA @ 3.3v <35mA @ 5.0v

### ELECTRICAL SPECIFICATIONS - GNSS ANTENNA, continued

DC Voltage	Nominal Impedance	Noise Figure	VSWR
2.7-5.0 VDC	50 ohms	1.5 dB	1.5:1 maximum

### MECHANICAL SPECIFICATIONS

Dimensions	Weight	Shock	Vibration
1.85" x 0.32" (47 x 8 mm)	.56 oz (16 g)	Vertical axis 50G Other axes 30G	3 axis, sweep = 15 min 10 - 200 Hz log sweep: 3G

### ENVIRONMENTAL SPECIFICATIONS

Temperature Range	ESD Circuit Protection	Humidity
-40°C to +85°C operating	15 KV	95% max (non condensing)

## 18 mm Compact Embedded GPS Antenna



The Compact 1857D Embedded GPS antenna is ideal for GPS enabled ruggedized PDAs, laptops and portable GPS Handhelds. The 1857D antenna features a custom tuned frequency ceramic patch element, ESD circuit protection, a two-stage low noise amplifier and a SAW filter, enabling the 1857D to provide great out-of-band signal rejection performance, consistent and clear signal while minimizing loss-of-lock in a very small form factor.



1857D

### Features

- Very compact form factor
- 15 KV ESD circuit protection
- 2.7 to 5 Volt operation
- Ideal for embedded applications

### STANDARD CONFIGURATION

Model	Cable	Connector
1857D	6" (15 cm) RG174	MCX right angle

### ELECTRICAL SPECIFICATIONS - GNSS ANTENNA

Frequency Range	LNA Gain	Element Gain	Out of Band Rejection	Current Draw	DC Voltage
1575.42 ± 10 MHz	@ 3.3 VDC: 28 dB @ 5 VDC: 30 dB	1 dBic	± 15 MHz: 5 dB ± 20 MHz: 10 dB ± 30 MHz: 32 dB ± 40 MHz: 40 dB	<20mA @ 3.3v <35mA @ 5.0v	2.7 - 5 VDC

### ELECTRICAL SPECIFICATIONS - GNSS ANTENNA, continued

Noise Figure	VSWR	Polarization	Nominal Impedance
1.5 dB (typical)	1.5:1 maximum	Right hand circular	50 ohms

### MECHANICAL & ENVIRONMENTAL SPECIFICATIONS

Dimensions	Weight	Temperature Range	Humidity
0.71" L x 0.71" W x 0.28" H (18 x 18 x 7 mm)	0.28 oz (8 g)	-40°C to +85°C operating	95% max (non condensing)



## 13 mm Compact Embedded GPS Antenna

The Compact 1357D Embedded GPS antenna is ideal for GPS enabled ruggedized PDAs, laptops and portable GPS Handhelds. The 1357D antenna features a compact ceramic patch element, ESD circuit protection, a low noise amplifier and a SAW filter, enabling the 1357D to provide great out-of-band signal rejection performance, consistent and clear signal while minimizing loss-of-lock in an extremely small form factor.

### Features

- Ultra-compact form factor
- 15 KV ESD circuit protection
- 2.7 to 5 V operation
- Ideal for embedded applications



1357D

### STANDARD CONFIGURATION

Model	Cable	Connector
1357D	6" (15 cm) CO-6F.FH-SB cable (1.5 mm diameter)	H.FL

### ELECTRICAL SPECIFICATIONS - GNSS ANTENNA

Frequency Range	LNA Gain	Element Gain	Polarization
1575.42 ± 10 MHz	@ 3.3 VDC: 28 dB @ 5 VDC: 30 dB	0.5 dBic	Right hand circular

### ELECTRICAL SPECIFICATIONS - GNSS ANTENNA, continued

Out of Band Rejection	Current Draw	DC Voltage	Noise Figure
± 15 MHz: 5dB ± 20 MHz: 10 dB ± 30 MHz: 32 dB ± 40 MHz: 40 dB	<20mA @ 3.3v <35mA @ 5.0v	2.7 - 5 V	1.5 dB (typical)

### MECHANICAL & ENVIRONMENTAL SPECIFICATIONS

Dimensions	Weight	Temperature Range	Humidity
.63" L x .63" W x .23" H (16 x 16 x 5.8 mm)	0.21 oz (5.9 g)	-40°C to +85°C operating	95% max (non condensing)

## Precision Performance WAAS Antenna

Specifically designed to meet the demanding standards necessary for worldwide WAAS aviation operations, model 2225NW features both advanced spiral technology and a self-complementary element structure.

The antenna's low multipath error design has the lowest phase error of all antenna element designs. The spiral minimizes manufacturing errors and its self-complementary currents act to center antenna phase. The large cavity design (1/5 lambda) allows for similar, choke slot-like (radiation pattern), roll off at the horizon and a superior front-to-back ratio.



2225NW

### STANDARD CONFIGURATION

Model	Connector	Mount	Housing Color
2225NW	RF Side: N Female, flange-mount DC Side: N Male, cable-terminated	Interface to PELCO mount (mount not included)	White

### ELECTRICAL SPECIFICATIONS - GNSS ANTENNA

Frequency Range	LNA Gain	Element Gain	Polarization	Current Draw	DC Voltage
1575.42 MHz (L1 band) 1227.60 MHz (L2 band) 1176.45 MHz (L5 band)	48 ± 3 dB	> -3 dBic @ El=90° (zenith) ≥ -9.0 dBic @ El=5° (L1) > -3 dBic @ El=90° (zenith) ≥ -5.0 dBic @ El=5° (L2) > -3 dBic @ El=90° (zenith) ≥ -9.0 dBic @ El=5° (L5)	Right hand circular	≤ 200 mA @ 24 V	24 V

### ELECTRICAL SPECIFICATIONS - GNSS ANTENNA, continued

VSWR	Elevation Boresight	Noise Figure	1 dB Compression	Axial Ratio	Bandwidth:
< 1.5:1 ± 10 MHz < 2.0:1 @ ± 10 MHz (all bands)	90° above horizon	2.0 dB	≥ 10 dBm	8 dB (max) elevation from 5°- 45° 4 dB (max) elevation above 45°	-1 dB +/-10 MHz (L1, L2, L5) -80 dB +/-50 MHz (L1, L2, L5)

### ELECTRICAL SPECIFICATIONS - GNSS ANTENNA, continued

Bandpass Ripple	Group Delay Ripple:	Azimuth Half Power Beamwidth	Elevation Half Power Beamwidth	Nominal Impedance
1.5 dB +/-10 MHz (L1, L2, L5)	3 ns @ L1 +/-10 MHz 4 ns @ L2 +/-10 MHz 4 ns @ L5 +/-10 MHz	Omnidirectional	66° (L1 band) 90° (L2 band) 103° (L5 band)	50 ohms

### MECHANICAL & ENVIRONMENTAL SPECIFICATIONS - GNSS ANTENNA

Dimensions	Weight	Temperature Range	Wind Operational
24.5" H x 12.8" OD (61.27 x 32.5 cm)	30 lbs (13.6 kg)	-58°F to 158°F	0-100 mph



## GPS L1/L2, L Band & GLONASS L1 Active, High Performance Magnetic Mount Antenna

The GPS-LB12GL-MAG is designed to meet DO-160 standards for airborne equipment. The Arinc 743 form factor is robust with a hermetic seal for long lasting, trouble free deployment and durability.

### Applications

- Military Vehicle Tracking & Asset Tracking
- Precision Agriculture
- Differential Correction



GPS-LB12GL-MAG

### STANDARD CONFIGURATION

Model	Connector	Mount	Housing Color
GPS-LB12GL-MAG	SMA Female	Magnetic mount with > 20 lb pull force	White*

### ELECTRICAL SPECIFICATIONS - GNSS ANTENNA

Frequency Range	LNA Gain	Element Gain	Polarization	Current Draw	DC Voltage
1575.42 ± 10 MHz (GPS L1) 1227.60 ± 10 MHz (GPS L2) 1525.00-1610.00 MHz (L Band) 1602.00 ± 10 MHz (GLONASS L1)	33 dB ± 4 dB	@ 10° Elev.: -5 dBic (GPS L1), -6 dBic (GPS L2), -7 dBic (L Band), -7 dBic (GLONASS L1)  @ 90° Elev.: 2 dBic (GPS L1), 3 dBic (GPS L2), 1 dBic (L Band), 0 dBic (GLONASS L1)	Right hand circular	42 mA typical ≤ 50 mA	3.3-12.0 VDC through connector 30 V survival voltage

### ELECTRICAL SPECIFICATIONS - GNSS ANTENNA, continued

VSWR	Noise Figure	Axial Ratio	Nominal Impedance
< 2.0:1	2.5 dB (typical)	@ 30° Elev.: ≤ 11 dB (GPS L1), ≤ 7 dB (GPS L2), ≤ 11 dB (L Band), ≤ 11 dB (GLONASS L1) @ 45° Elev.: ≤ 9 dB (GPS L1), ≤ 6 dB (GPS L2), ≤ 9 dB (L Band), ≤ 9 dB (GLONASS L1) @ 90° Elev.: ≤ 4 dB (GPS L1), ≤ 2 dB (GPS L2), ≤ 4 dB (L Band), ≤ 4 dB (GLONASS L1)	50 ohms

### MECHANICAL SPECIFICATIONS

Dimensions	Weight	Housing Material
119.6 L x 80.4 W x 28 H mm (4.71" x 3.17" x 1.10")	6.8 oz nominal	ASA

### ENVIRONMENTAL SPECIFICATIONS

Temperature Range	Altitude	ESD Protection	Immersion	Vibration
-40°C to 85°C	70,000 ft	15kV	Mil Std 810F, Method 512.4, Procedure 1 with immersion depth 2 m	Mil Std 810F, Method 514.5, Procedure II, Category 5

\* Custom color options available upon request.



# GPS L1/L2 Active, High Gain, High Performance Magnetic Mount Antenna

The GPS-L1L2-28MAG is designed to meet MIL461 standards for Electromagnetic Interference (EMI) as well as DO-160 standards for airborne equipment. The package is robust with a hermetic seal for long lasting, trouble free deployment and durability.



GPS-L1L2-28MAG

### Applications

- Military Vehicle Tracking & Asset Tracking
- Precision Agriculture
- Differential Correction

### STANDARD CONFIGURATION

Model	Connector	Mount	Housing Color
GPS-L1L2-28MAG	SMA Female	Magnetic mount with > 20 lb pull force	White*

### ELECTRICAL SPECIFICATIONS - GNSS ANTENNA

Frequency Range	LNA + Antenna Gain	Polarization	Current Draw
1575.42 ± 10 MHz (GPS L1) 1227.60 ± 10 MHz (GPS L2)	35 dB +/- 3 dB	Right hand circular	37 mA typical ≤ 50 mA

### ELECTRICAL SPECIFICATIONS - GNSS ANTENNA, continued

DC Voltage	Noise Figure	VSWR	Axial Ratio		Nominal Impedance
			GPS L1	GPS L2	
2.5-5.5 VDC through connector 24 V survival voltage	2.5 dB (maximum)	2.0:1 (typical) 2.5:1 (maximum)	@ 30° Elev.: < 4 dB @ 45° Elev.: < 3 dB @ 70° Elev.: < 2 dB	< 5 dB < 3 dB < 2 dB	50 ohms

### MECHANICAL SPECIFICATIONS

Dimensions	Weight	Housing Material
2.75" D x 0.95" H	5.7 oz nominal	ASA

### ENVIRONMENTAL SPECIFICATIONS

Temperature Range	Altitude	ESD Protection	Immersion	Vibration
-40°C to 85°C	70,000 ft	Mil. Std. 464A	Mil Std 810F, Method 512.4, Procedure 1 with immersion depth 2 m	Mil Std 810F, Method 514.5, Procedure II, Category 5

\* Custom color options available upon request.



## Multi-GNSS High Performance Antenna

**GNSS Systems: 1150 - 1290 MHz (GPS L2/L5; GALILEO E5A/E5B/E6; GLONASS L2/L3; BEIDOU B2/B3)  
1500 - 1615 MHz (GPS L1; GALILEO E1; GLONASS L1; BEIDOU B1/B1-2)**

The GNSS-L125-TNC is a multi-GNSS high performance antenna designed to meet stringent AAR environmental standards. The antenna features a multi-stacked patch design covering global GNSS frequencies, a multi-stage LNA and advanced filtering to combat the effects of adjacent band interference. The antenna has a hermetic seal, is AAR tested and approved.

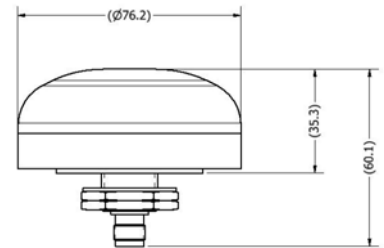

GNSS-L125-TNC

### Features

- Full Multi-GNSS Compatibility
- Advanced Out-of-Band Filtering
- AAR Compliant
- Excellent Multipath Mitigation
- IP67 ingress protection

### Applications

- PTC Rolling Stock Tracking
- Military Vehicle Tracking & Asset Tracking
- Precision Agriculture
- Differential Correction

### ELECTRICAL SPECIFICATIONS - ALL BANDS

LNA Gain	Nominal Impedance	Polarization	ESD Protection	VSWR	Noise Figure	DC Voltage	DC Current	Out-of-Band Rejection	
28dB +/- 3dB	50 ohms	Right Hand Circular	>15kV	<2.0:1 (typ.)	3.0 dB (typ.)	2.5-12.0 VDC	37 mA (typ.) <50 mA (max.)	<1050 MHz >80 dB <1125 MHz >30 dB >1350 MHz >70 dB	<1450 MHz >70dB >1690 MHz >30dB >1730 MHz >80dB

### ELECTRICAL SPECIFICATIONS - BAND SPECIFIC

Band	Gain @ 10° Elevation	Gain @ 90° Elevation	Axial Ratio @ 30° Elevation	Axial Ratio @ 45° Elevation	Axial Ratio @ 90° Elevation
GPS L1	-5 dBic	2 dBic	≤ 2.5 dB	≤ 2.5 dB	≤ 2.5 dB
GPS L2	-6 dBic	3 dBic			
GPS L5	-7 dBic	1 dBic			
GLONASS L1	-7 dBic	0 dBic			
GLONASS L2	-8 dBic	0 dBic			
GLONASS L3	-4 dBic	3 dBic			
GALILEO E1	-5 dBic	2 dBic			
GALILEO E5	-4 dBic	3 dBic			
GALILEO E6	-4 dBic	3 dBic			
BEIDOU B1	-4 dBic	3 dBic			
BEIDOU B1-2	-4 dBic	3 dBic			
BEIDOU B2	-5 dBic	2 dBic			
BEIDOU B3	-8 dBic	0 dBic			

### MECHANICAL & ENVIRONMENTAL SPECIFICATIONS

Antenna Dimensions	Antenna Weight	Connector	Mounting Method	Radome Color	IP Rating	Radome Seal	Environmental Rating
3.0" D x 1.4" H (76.2 x 35.3 mm)	7.4 ounces	TNC Female	3/4" thru-hole or bracket	White	IP67	Rubber Gasket	AAR Compliant

## Multi-GNSS, Passive High Performance Antenna

**GNSS Systems: 1150 - 1290 MHz (GPS L2/L5; GALILEO E5A/E5B/E6; GLONASS L2/L3; BEIDOU B2/B3)  
1500 - 1615 MHz (GPS L1; GALILEO E1; GLONASS L1; BEIDOU B1/B1-2)**

The GNSS-L125-PSTNC is a multi-GNSS high performance antenna designed to meet stringent AAR environmental standards. The antenna features a multi-stacked patch design covering global GNSS frequencies. This antenna is passive and has been designed for applications where the active electronics are collocated with the receiver as well as for reradiating GNSS applications. The antenna has a hermetic seal, is AAR tested and approved.

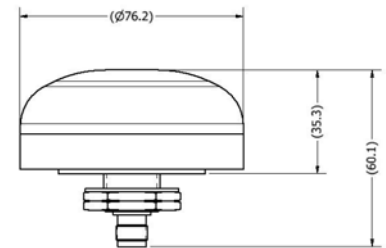

GNSS-L125-PSTNC

### Features

- Full Multi-GNSS Compatibility
- Passive RF Design
- AAR Compliant
- IP67 ingress protection

### Applications

- PTC Rolling Stock Tracking
- Military Vehicle Tracking & Asset Tracking
- GNSS Indoor Reradiating Applications

### ELECTRICAL SPECIFICATIONS - ALL BANDS

Nominal Impedance	Polarization	ESD Protection	VSWR
50 ohms	Right Hand Circular	>15kV	<2.0:1 (typ.)

### ELECTRICAL SPECIFICATIONS - BAND SPECIFIC

Band	Gain @ 10° Elevation	Gain @ 90° Elevation	Axial Ratio @ 30° Elevation	Axial Ratio @ 45° Elevation	Axial Ratio @ 90° Elevation
GPS L1	-5 dBic	2 dBic	≤ 2.5 dB	≤ 2.5 dB	≤ 2.5 dB
GPS L2	-6 dBic	3 dBic			
GPS L5	-7 dBic	1 dBic			
GLONASS L1	-7 dBic	0 dBic			
GLONASS L2	-8 dBic	0 dBic			
GLONASS L3	-4 dBic	3 dBic			
GALILEO E1	-5 dBic	2 dBic			
GALILEO E5	-4 dBic	3 dBic			
GALILEO E6	-4 dBic	3 dBic			
BEIDOU B1	-4 dBic	3 dBic			
BEIDOU B1-2	-4 dBic	3 dBic			
BEIDOU B2	-5 dBic	2 dBic			
BEIDOU B3	-8 dBic	0 dBic			

### MECHANICAL & ENVIRONMENTAL SPECIFICATIONS

Antenna Dimensions	Antenna Weight	Connector	Mounting Method	Radome Color	IP Rating	Radome Seal	Environmental Rating
3.0" D x 1.4" H (76.2 x 35.3 mm)	7.4 ounces	TNC Female	3/4" thru-hole or bracket	White	IP67	Gasket	AAR Compliant



## Multi-GNSS High Performance Antenna

**GNSS Systems: 1150 - 1290 MHz (GPS L2/L5; GALILEO E5A/E5B/E6; GLONASS L2/L3; BEIDOU B2/B3)  
1500 - 1615 MHz (GPS L1; GALILEO E1; GLONASS L1; BEIDOU B1/B1-2)**

The GNSS-L125-40TNC is a high gain, multi-GNSS high performance antenna designed to meet stringent AAR environmental standards. The antenna features a multi-stacked patch design covering global GNSS frequencies, a multi-stage LNA and advanced filtering to combat the effects of adjacent band interference. The antenna has a hermetic seal, is AAR tested and approved. This antenna comes with a 5 year warranty.

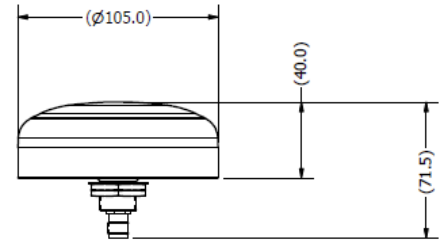

GNSS-L125-40TNC

### Features

- High Gain (40dB typ.)
- Advanced Out-of-Band Filtering
- AAR Compliant
- Excellent Multipath Mitigation
- IP67 ingress protection
- Full GNSS Compatibility

### Applications

- PTC Rolling Stock Tracking
- Military Vehicle & Asset Tracking
- Precision Agriculture
- Differential Correction
- GNSS Indoor Reradiation
- High Accuracy Time Sync

### ELECTRICAL SPECIFICATIONS - ALL BANDS

LNA Gain	Nominal Impedance	Polarization	ESD Protection	VSWR	Noise Figure	DC Voltage	DC Current	Out-of-Band Rejection
40 dB +/- 5 dB	50 ohms	Right Hand Circular	>15kV	<2.0:1 (typ.)	3.0 dB (typ.)	2.5-12.0 VDC	37 mA (typ.) <50 mA (max.)	<1050 MHz >80 dB <1125 MHz >30 dB >1350MHz >70 dB <1450 MHz >70 dB >1690 MHz >30 dB >1730 MHz >80 dB

### ELECTRICAL SPECIFICATIONS - BAND SPECIFIC

Band	Gain @ 10° Elevation	Gain @ 90° Elevation	Axial Ratio @ 30° Elevation	Axial Ratio @ 45° Elevation	Axial Ratio @ 90° Elevation
GPS L1	-5 dBic	2 dBic	≤ 2.5 dB	≤ 2.5 dB	≤ 2.5 dB
GPS L2	-6 dBic	3 dBic			
GPS L5	-7 dBic	1 dBic			
GLONASS L1	-7 dBic	0 dBic			
GLONASS L2	-8 dBic	0 dBic			
GLONASS L3	-4 dBic	3 dBic			
GALILEO E1	-5 dBic	2 dBic			
GALILEO E5	-4 dBic	3 dBic			
GALILEO E6*	-4 dBic	3 dBic			
BEIDOU B1	-4 dBic	3 dBic			
BEIDOU B1-2	-4 dBic	3 dBic			
BEIDOU B2	-5 dBic	2 dBic			
BEIDOU B3	-8 dBic	0 dBic			

### MECHANICAL & ENVIRONMENTAL SPECIFICATIONS

Antenna Dimensions	Antenna Weight	Connector	Mounting Method	Radome Color	IP Rating	Radome Seal	Environmental Rating
4.13" D x 1.57" H (105.0 x 40.0 mm)	13.6 ounces	TNC Female	3/4" thru-hole or bracket	White	IP67	Gasket	AAR Compliant



# GPS/GLONASS High Performance Asset Tracking & Time Sync Micro Helix Antenna

PCTEL's GEO-GNSS-AC-S1 is a robust, active, high performance antenna covering both GPS L1 and GLONASS L1 frequency bands. PCTEL's proprietary filtering design allows wideband coverage while achieving superior out-of-band rejection. This antenna is ideal for performance in critical asset tracking and network timing synchronization applications.

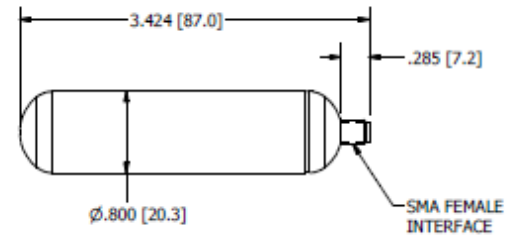

**GEO-GNSS-AC-S1**

## Features

- GPS L1 & GLONASS L1 Frequencies
- Custom-Tuned Micro Helix Element
- High Rejection Filtering
- 26.5 dB Gain
- IP67\* Ingress Protection
- 

## Applications

- Defense Radio Communications
- Handheld Devices
- Body Worn Asset Tracking
- Public Safety Emergency Responders
- Industrial Network Synchronization

## STANDARD CONFIGURATION

Model	Connector	Housing Color
GEO-GNSS-AC-S1	SMA Female	Black

## ELECTRICAL SPECIFICATIONS - GNSS ANTENNA

Frequency Range	Amplifier Gain	Polarization	Out of Band Rejection	Current Draw
1574-1610 MHz	@ 3.0 VDC: 26.5 dB (typical);	Right hand circular	f0 = 1586 MHz f0 ± 50 MHz: ≥ 40 dBc	< 20 mA (typical)

## ELECTRICAL SPECIFICATIONS - GNSS ANTENNA, continued

DC Voltage	Noise Figure	Element Gain	Nominal Impedance
2.5-5.5 V (operating) ≤ 12.0 V (survivability)	< 2.0 dB (typical)	- 2.0 dBic @ GPS L1 - 2.5 dBic @ GLONASS L1	50 ohms

## MECHANICAL & ENVIRONMENTAL SPECIFICATIONS

Dimensions	Weight	Radome Material	Connector	Temperature Range	Ingress Protection
0.8 x 3.4 inches (20.3 x 87.0 mm)	1.23 oz (35 g)	ABS	SMA Female	-40°C to +85°C operating	IP67*

\*When installed according to the manufacturer's installation instructions.



# GPS/GLONASS High Performance Asset Tracking & Time Sync Micro Helix Antenna

PCTEL's GEO-GNSS-PS-S1 is a robust, passive, high performance antenna covering both GPS L1 and GLONASS L1 frequency bands. This antenna is ideal for performance in critical asset tracking and network timing synchronization applications.

## Features

- GPS L1 & GLONASS L1 Frequencies
- Custom-Tuned Micro Helix Element
- IP67\* Ingress Protection
- 

## Applications

- Defense Radio Communications
- Handheld Devices
- Body Worn Asset Tracking
- Public Safety Emergency Responders
- Network Synchronization

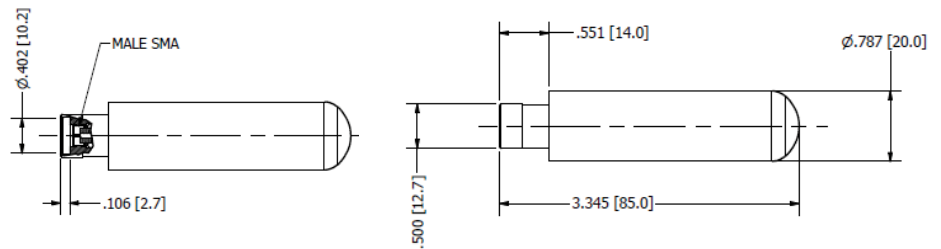

**GEO-GNSS-PS-S1**

## STANDARD CONFIGURATION

Model	Connector	Mount	Housing Color
GEO-GNSS-PS-S1	SMA Male	Direct Mount	Black

## ELECTRICAL SPECIFICATIONS - GNSS ANTENNA

Frequency Range	Gain	VSWR	Nominal Impedance	Polarization
1574-1610 MHz	1.5 dBic @ GPS L1 -2 dBic @ GLONASS L1	≤ 2.0:1 (typical) 2.5:1 (maximum)	50 ohms	Right hand circular

## MECHANICAL & ENVIRONMENTAL SPECIFICATIONS

Dimensions	Weight	Radome Material	Ingress Protection	Temperature Range
0.787" Dia x 3.345" H (20.x 85 mm)	1.23 oz (35 g)	ASA	IP67*	-40°C to +85°C operating

\*When installed according to the manufacturer's installation instructions.

## 12700 Series, Airborne Antennas

PCTEL's 12700 series antennas are robust, rigorously tested and environmentally sealed units suitable for a wide variety of GPS applications, including vehicle tracking, marine and airborne navigation.

These antennas have been tested to five DO-160 environmental test requirements, including:

- Altitude. RTCA/DO-160E, Section 4.6.1, Category F2
- Temperature and Temperature Variation Test. RTCA/DO-160E, Sections 4 and 5, Categories F2 and A
- Humidity. RTCA/DO-160D, Section 6. Category C-External Humidity Environment.
- Mechanical Shock RTCA/DO-160E, Section 7.0, Category B, Operational
- Vibration Test. RTCA/DO-160E, Section 8.0, Curves C, L, M, and Y



1270FW

They feature a sealed o-ring that protects them against severe environmental conditions for reliable, long-lasting performance. Their radome is constructed of high grade polymer resin for UV and abrasion resistance. They will resist all de-icing fluids, jet fuels, and standard cleaning solvents.

### STANDARD CONFIGURATION

Model	Mount	Connector	Housing Color
1270FW 1271FW 1273FW	Surface mount four hole pattern	TNC Female	White

### ELECTRICAL SPECIFICATIONS - GNSS ANTENNA

Model	LNA Gain	Frequency Range	Element Gain	Polarization	Noise Figure	Current Draw
1270FW 1271FW 1273FW	26 dB @ 5 V Passive 35 dB @ 5 V	1575.42 ± 10 MHz (GPS L1)	+ 4.5 dBic nominal at zenith	Right hand circular	2.5 dB nominal	≤ 30 mA - ≤ 40 mA

### ELECTRICAL SPECIFICATIONS - GNSS ANTENNA, continued

Model	DC Voltage	VSWR	Nominal Impedance	Polarization
1270FW 1271FW 1273FW	3-9 VDC (working voltage)	< 2.0:1	50 ohms	Right hand circular

### MECHANICAL & ENVIRONMENTAL SPECIFICATIONS

Model	Dimensions	Weight	Temperature Range	Humidity
1270FW 1271FW 1273FW	3.4" H x 2.2" W	3.6 oz nominal	-40°C to +85°C	95%



## 1210FW GPS Airborne Puck Antenna

The 1210FW antenna is a robust, rigorously tested and environmentally sealed unit suitable for a wide variety of GPS applications. This antenna is ideal for vehicle tracking, marine or airborne navigation installations requiring maximum security and durability.

The 1210FW antenna has been tested to DO-160 environmental test requirements and is designed to meet Arinc 743 specifications. It features a dual o-ring seal that protects the antenna against severe environmental conditions for reliable, long-lasting performance. The radome is constructed of high grade polymer resin for UV and abrasion resistance. It will resist all de-icing fluids, jet fuels, and standard cleaning solvents.

The 1210FW antenna is hard mounted through a unique single hole feed structure and includes gaskets to prevent air and water leaks. The 1210FW features a 26dB gain Low Noise Amplifier.



1210FW

### STANDARD CONFIGURATION

Model	Mount	Connector	Housing Color
1210FW	Through hole 5/8-18UNC-2A thread	TNC Female Bulkhead	White

### ELECTRICAL SPECIFICATIONS - GNSS ANTENNA

Model	LNA Gain	Frequency Range	Element Gain	Noise Figure	Current Draw
1210FW	26 dB	1575.42 ± 10 MHz (GPS L1)	+4.5 dBiC nominal at zenith	2.5 dB maximum	25 mA typical ≤40 mA

### ELECTRICAL SPECIFICATIONS - GNSS ANTENNA, continued

Model	DC Voltage	VSWR	Nominal Impedance	Polarization
1210FW	5-9 VDC through connector	2.0:1 maximum	50 ohms	Right hand circular

### MECHANICAL SPECIFICATIONS

Model	Dimensions	Weight	NATO Stock Number	Housing Material
1210FW	2.7" OD x 0.75" D	3 oz nominal	5820 99 147 2772 (for 1213FW only)	Aluminum

### ENVIRONMENTAL SPECIFICATIONS

Model	Temperature Range	Humidity
1210FW	-40°C to +85°C	95%

## Iridium® Magnet Mount Passive Antenna



The 9211D is a high performance passive 1616 to 1626.5 MHz, RHCP antenna, specifically designed to operate with the Iridium® Satellite communication system. It features a precisely tuned custom ceramic patch antenna element and a matching network. The 9211D antenna is enclosed in a rugged, fully weatherproof housing that allows the Iridium Satellite SBD modem to be mounted away from the elements, yet fully meeting Iridium's radiated power requirements. Its top cover (radome) is composed of high-grade GE plastic and the zinc base is equipped with both screw holes and magnets for ease of installation. The antenna comes standard with 6.6' (2 meters) of high quality Shikoku coaxial cable and an SMA male connector.



9211D

### Features

- Ideal for Iridium® Satellite Short Data Service applications
- Weather proof housing
- Magnet or screw mount
- RoHS compliant

### STANDARD CONFIGURATION

Model	Cable	Connector*	Mount
9211D	6.6 feet (2 meters) highly flexible 174 sized cable Cable Loss: 1.3 dB/m typical	SMA Male	Magnetic (5 lb lift-off force) or permanent (pre-threaded for 3 x M2.5 screws)

### ELECTRICAL SPECIFICATIONS - GNSS ANTENNA

Frequency Range	Gain	Polarization	VSWR	Axial Ratio
1616-1626.5 MHz	4 dBic @ Zenith (maximum)	Right hand circular	< 2.0:1	3 dB @ Zenith (maximum)

### MECHANICAL SPECIFICATIONS

Dimensions	Weight	Housing Material
2.1" L x 2.3" W x 0.54" H (52.1 x 58.9 x 13.6 mm)	0.26 lbs (120 g)	ASA

### ENVIRONMENTAL SPECIFICATIONS

Temperature Range	Humidity	Ingress Protection
-40°C to +85°C operating	95% max (non condensing)	IP67

\*Consult PCTEL Customer Service for other connector options.



## GPS L1/GLONASS L1 Active Magnetic Mount Antenna



The 8117D GPS L1/GLONASS antenna is a high performance antenna with a wide voltage range, ideally suited to telematics platforms for use in vehicle mounted applications. With a wideband patch, this antenna was designed to operate at GPS L1 as well as GLONASS L1 frequencies. Using internal magnets or screw mount holes, the antenna can be installed almost anywhere on a vehicle allowing for greater flexibility. The 8117D antenna features 28 dB gain low noise amplifier and a SAW filter. With 2.7 to 5 volt operation, the antenna can be used with the vast majority of GPS L1 and GLONASS systems available.



8117D

### Features

- GPS L1 & GLONASS L1 Frequencies
- Voltage range 2.5 – 5 V
- LNA 28 dB gain typical
- Low noise figure 1.5 dB

### STANDARD CONFIGURATION

Model	Cable	Connector	Mount
8117D	9.8' (3 meters) highly flexible 174 sized cable	Male SMA standard	Magnetic (5 lb lift-off force) or permanent (pre-threaded for 3 x M2.5 screws)

### ELECTRICAL SPECIFICATIONS - GNSS ANTENNA

Frequency Range	LNA Gain	Element Gain	Polarization
1568-1618 MHz (typical)	@ 3.3 VDC: 28 dB $\pm$ 1.5 dB (typical) @ 5 VDC: 30 dB $\pm$ 1.5 dB (typical)	3 dBic @ 90° -2 dBic @ 20°	Right hand circular

### ELECTRICAL SPECIFICATIONS - GNSS ANTENNA, continued

Current Draw	Out of Band Rejection	DC Voltage	Noise Figure
<20mA @ 3.3v <35mA @ 5.0v	@ 1535 MHz: > 45 dB @ 1540 MHz: > 30 dB @ 1545 MHz: > 20 dB @ 1670 MHz: > 40 dB @ 1650 MHz: > 30 dB @ 1640 MHz: > 20 dB	2.5-5 VDC (operating)*	1.5 dB (typical)

### MECHANICAL & ENVIRONMENTAL SPECIFICATIONS

Dimensions	Weight	Housing Material	Temperature Range	Ingress Protection
2.05" L x 2.33" W x 0.54" H (52.1 x 59.2 x 13.6 mm)	0.26 lbs (120 g)	ASA	-40°C to +85°C operating	IP67**

\* User may see a degradation of 2 dB gain between 2.5-2.7 VDC from advertised specification. \*\* When installed according to the manufacturer's installation instructions.